

Zips 3.0

High Security Adjustable Noose Sensor &
High Security Adjustable Noose Sensor
with Secondary Sensor
ZB2002 & ZB2003

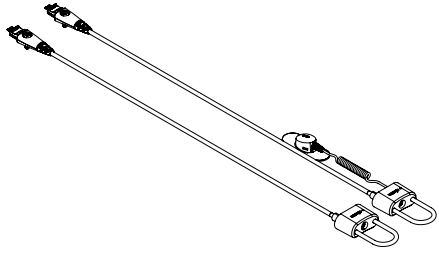

- 1 Use the TT20 bit in the multitool to loosen the screw on the sensor housing.

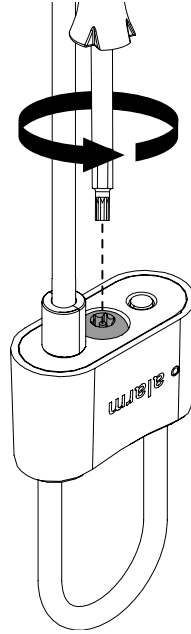

- 2 Slide the cable through the housing so that the loop will fit around the merchandise being displayed.

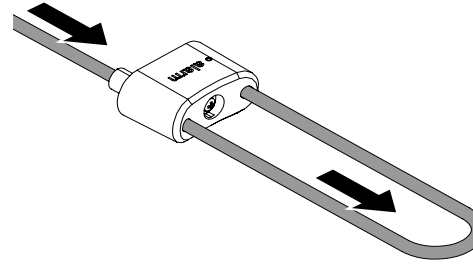

- 3 Place the loop around the merchandise.

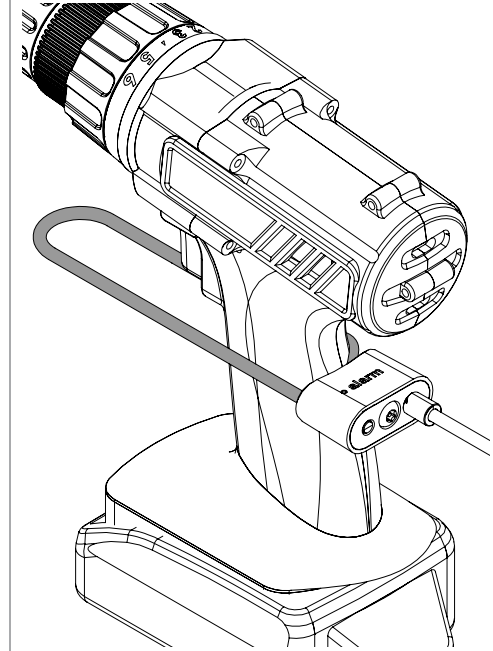

- 4 Pull the slack from the cable so that it is secure around the merchandise.

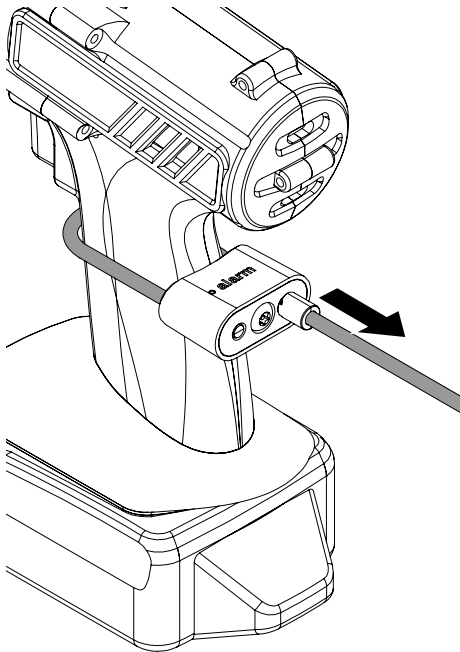

- 5 Tighten the screw using the TT20 bit.

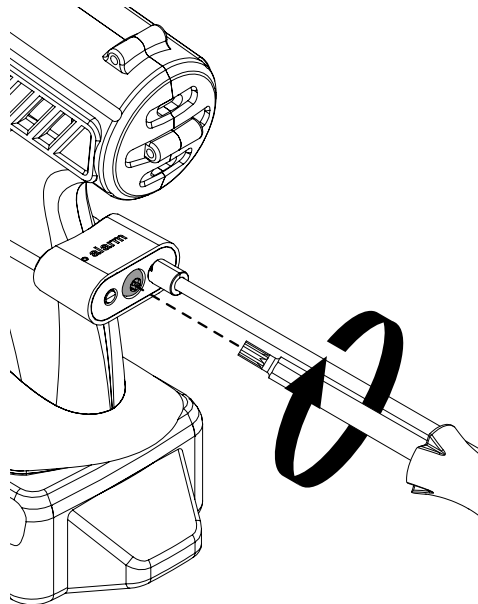

- 6 **If using a noose sensor with a secondary sensor (ZB2003):**
If the merchandise has a detachable feature that needs to be protected (battery pack, accessory, etc.), use the provided alcohol wipe to clean the part of it where the secondary sensor can be placed. Allow it to dry completely.

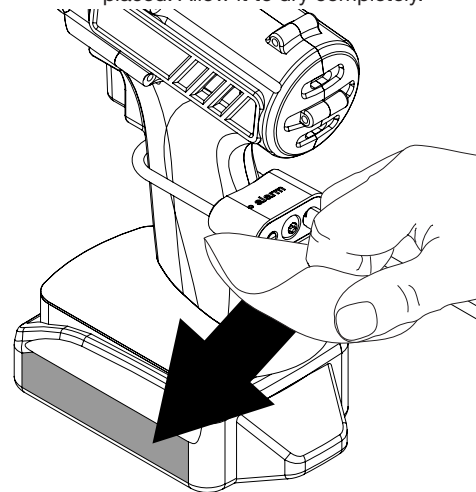

- 7 Peel the clear film from the secondary sensor.

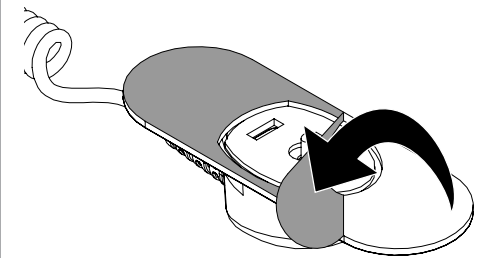

- 8** Place the secondary sensor onto the detachable feature. Apply pressure for at least 10 seconds.

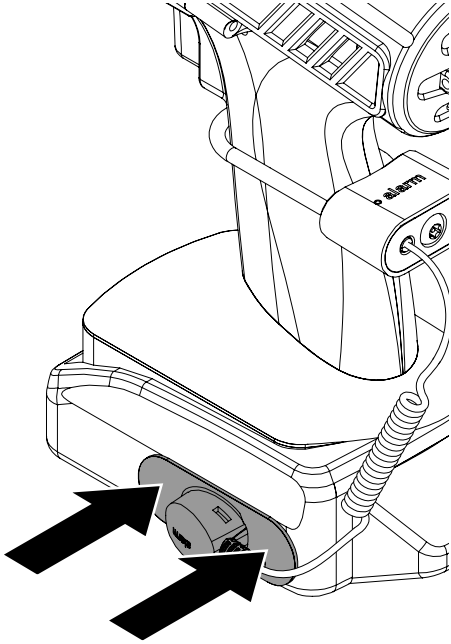

- 9** Plug the sensor into the alarm unit and align the hole in the sensor with the hole in the high security plate. Secure the sensor with the captured screw.

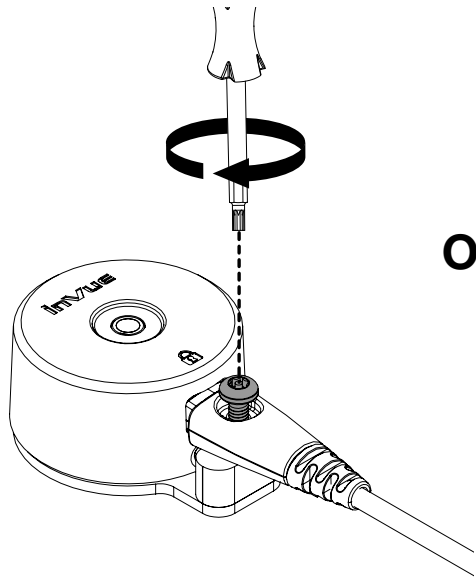

Or

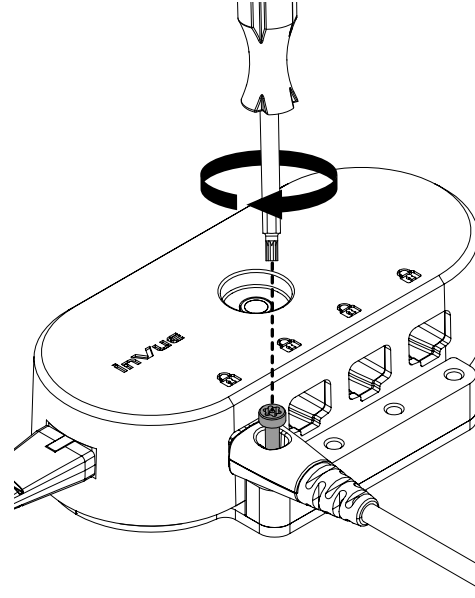

- 10a** **If using a Secondary EAS AM/RF Tag (ZB2013):**
Place the secondary tag under the sensor cable so that the cable runs down the center channel in the tag.

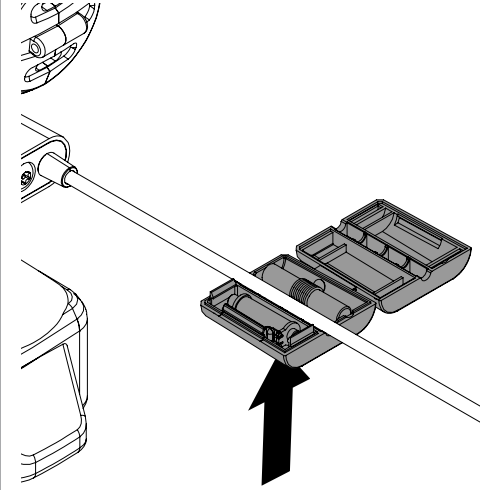

- 10b** Snap the tag closed over the cable.

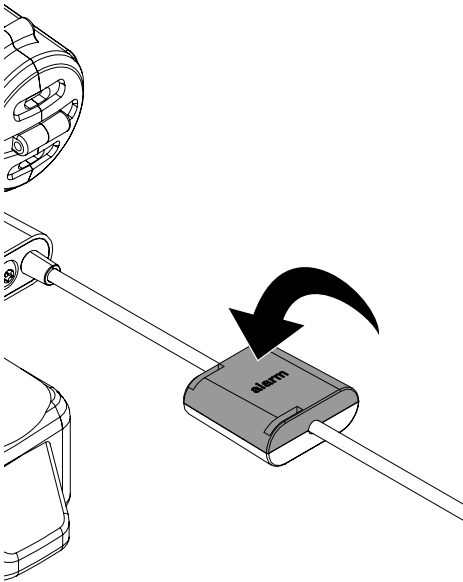

- 11a** To remove, first unscrew the sensor from the high security plate.

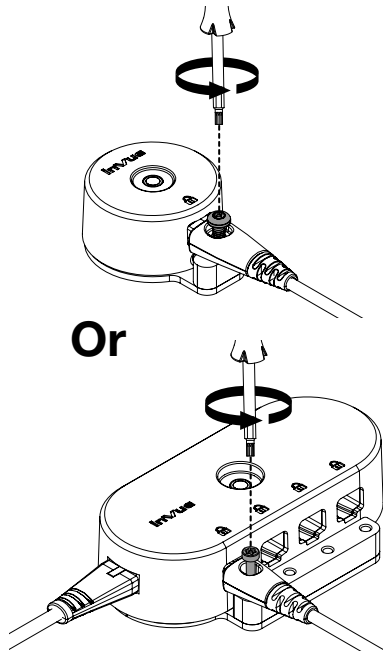

Or

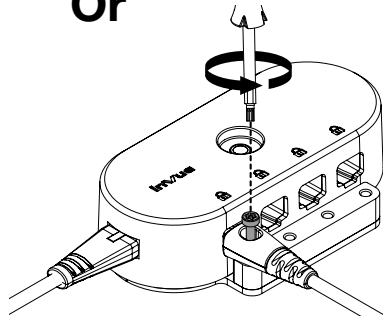

- 11b** Remove the sensor from the alarm unit by placing a charged and coded OneKEY on the IR lens and press the button to deactivate, then place the magnet key onto the lock icon on alarm unit above the sensor. Push in slightly and unplug the sensor.

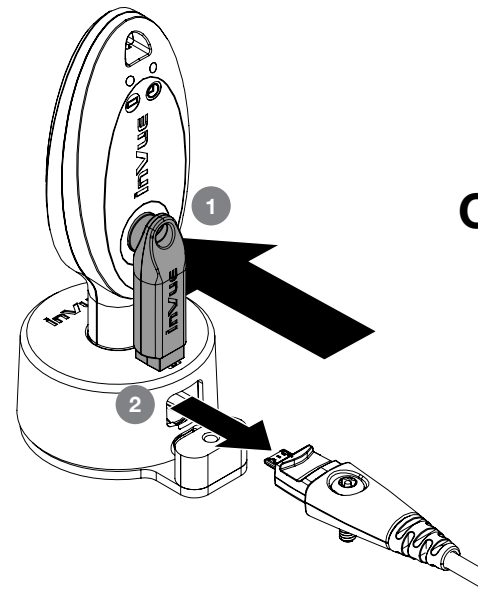

Or

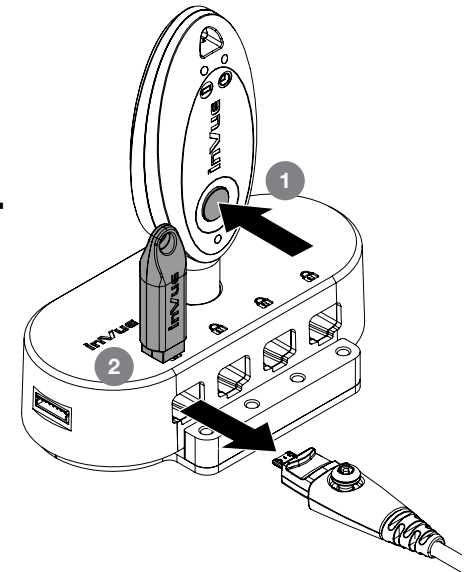



SD0640 Rev0 02/20/19



SABEL[®]

1300 551 662
info@sabel.com.au

© 2019 InVue Security Products Inc. All rights reserved.
InVue is a registered trademark of InVue Security Products.