

# OneKEY

## IR4 Usage Instructions

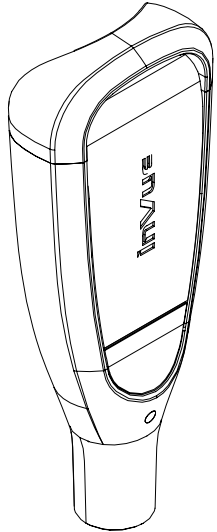

### At the start of the shift

- 1 Remove a fully charged OneKEY from the charger.

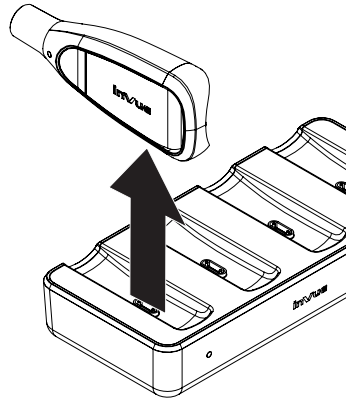

- 2 Check out the key by placing it onto the contacts on the OneKEY Manager (OKM).

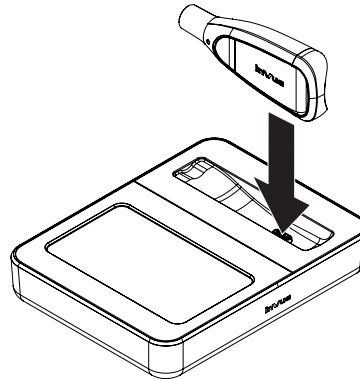

- 3

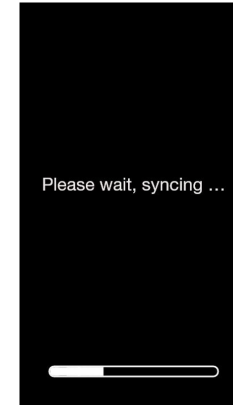

- 4 Select "Check out" on the screen of the OKM.

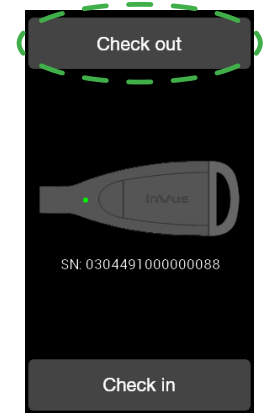

- 5 Enter the PIN and press the green key.

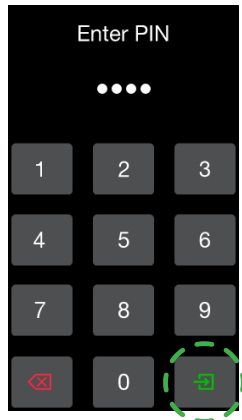

- 6

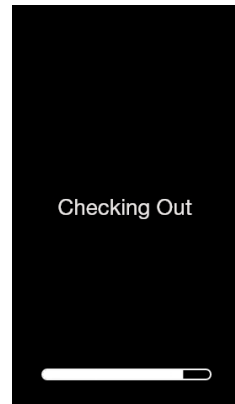

- 7 Your Key is now ready for use.

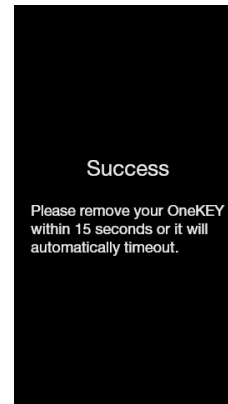

The Green LED light confirms the Key has been activated correctly.

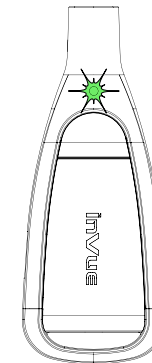

### At the end of the shift

- 1 Place the Key onto the contacts on the OKM.

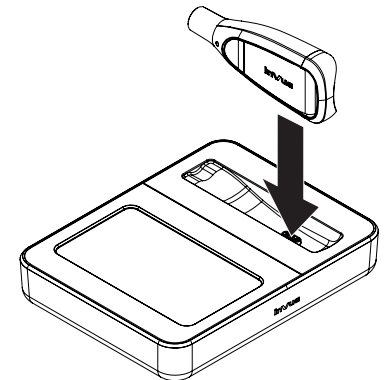

## OneKEY - IR4 Usage Instructions

**2**

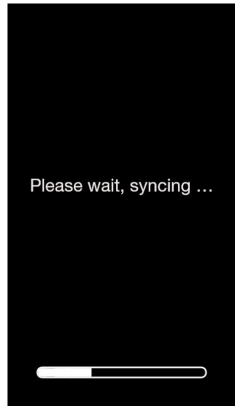

**3**

Select "Check In" on the screen of the OKM.



**4**

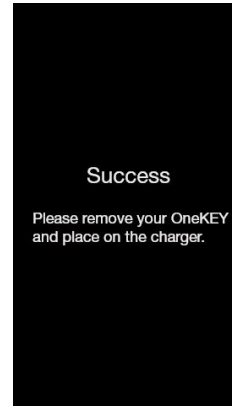

The **Red LED light** confirms the Key has been checked in correctly.

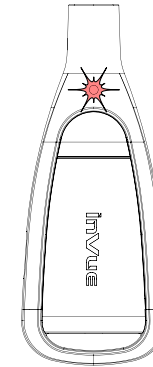

**5**

Return the Key to the charger for the next user.

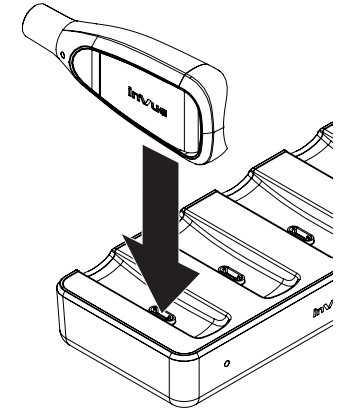

sabel.com.au

### Touchscreen Care Instructions:

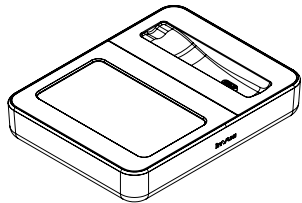

- If the screen becomes dirty, use a soft clean cloth to gently wipe the surface.
- Do NOT use flux, water, acetone, ethanol, isopropyl alcohol, toluene or ammonia (glass cleaner) when cleaning the surface.

### Battery Warnings:

- The Key & OneKEY Manager contain non-replaceable lithium ion batteries.
- The entire device should be recycled at an approved center for rechargeable batteries.
- Do not immerse in water.
- Do not place in a fire or excessive heat.
- Do not disassemble, puncture or pierce.

SD0753 Rev3 17/11/21



**SABEL**

© 2022 InVue Security Products Inc. All rights reserved. InVue is a registered trademark of InVue Security Products.